

rect value of a is the one which will give a set of $\log K_A - D^{-1}$ points for systems 1-4 which will lie on the extrapolation of the line through the points for systems 5-7. The four points at the left in Fig. 5 are those obtained using $\bar{a} = 9.0$ in (8). Within the validity of the various approximations made, this is in satisfactory agreement with the value $\bar{a} = 8.5$ found from the slope of Fig. 4. The points obtained using J (5.0) and J (7.0) in (8) lie below any reasonable extrapolation of the line approximating the points for systems 5-7. Now $J(a)$ represents the change in mobility due to the higher terms in the conductance equation, while $K_A(a)$ of course describes the ion-pair equilibrium. The agreement between the values of a from J and from K_A shows that charge-charge interaction suffices to describe the behavior of $\text{Bu}_4\text{N}\cdot\text{BPh}_4$ in the solvent system $\text{CH}_3\text{CN}-\text{CCl}_4$. From the viscosity coefficient F , the value of the hydrodynamic radius was found³ to be 5.4 \AA. , assuming the two ions to be of equal size. Center-to-center distance at contact, based on viscosity data, then would be 10.8 . This is in fair agreement with the electrostatic parameter, $\bar{a} \approx 9$, considering the completely different physical processes underlying the two results. Molecular models show that the nearest one can possibly bring the boron and nitrogen atoms of $\text{Bu}_4\text{N}\cdot\text{BPh}_4$ is about 7 \AA. ; this must represent the lowest possible bound for \bar{a} . The two ions are, of course, not spheres; the boron-nitrogen distance averaged over random orientations of the two ions at contact must certainly be larger than this minimum figure, as we found above from the conductance (and viscosity) data.

Finally, we consider the Walden products shown

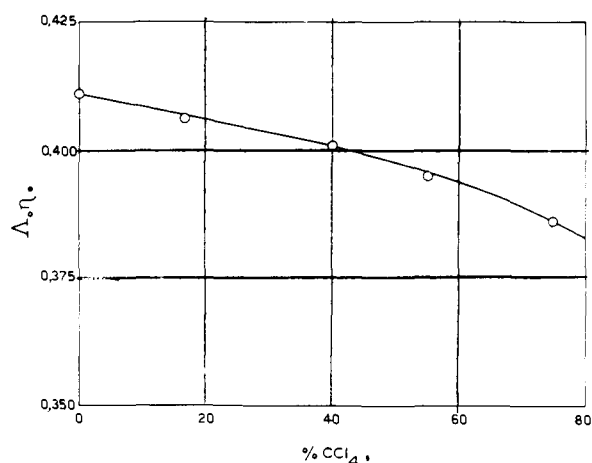

Fig. 6.—Dependence of Walden product on composition of solvent.

in Fig. 6. Both ions are much larger than the solvent molecules, and the system therefore should be a fairly good approximation to the Stokes model of a sphere in a continuum, for which the product $\Lambda_0\eta$ would be constant. Nevertheless, the product decreases by about 6% in going from acetonitrile to system 5; *i.e.*, as the viscosity increases from 0.00344 to 0.00550, the limiting conductance decreases faster than would correspond to Stokes friction. This result supports the tentative conclusion⁴ that an ion-dipole relaxation force between the moving ion and the dipolar molecules of the solvent must also be considered in the analysis of ionic motion.

ROME, ITALY

[CONTRIBUTION NO. 2383 FROM THE GATES AND CRELLIN LABORATORIES OF CHEMISTRY, CALIFORNIA INSTITUTE OF TECHNOLOGY]

A Rotor Aperture for the Determination of Optical Density within Rotating Ultracentrifuge Cells

BY E. ROBKIN, M. MESELSON AND J. VINOGRAD

RECEIVED SEPTEMBER 18, 1958

The design and applications of an exponential aperture for analytical ultracentrifuge rotors are described. Images of the rotating aperture and ultracentrifuge cell are recorded side by side on absorption photographs. Photometry of these photographs provides the necessary data for accurate evaluation of optical density within the rotating cell.

The photographic determination of optical density within a cell during the operation of the analytical ultracentrifuge is of importance in many experiments.¹ It is convenient in such work to employ the film within the linear range of its characteristic response to exposure and to measure its optical density with a photometer possessing linear response to film optical density. These two conditions are expressed by the relation

$$\beta \log \text{exposure} = \text{Pen Deflection} + f_1 \quad (1)$$

where β and f_1 , are constants characteristic of the film specimen and the photometer.

(1) T. Svedberg and K. O. Pederson, "The Ultracentrifuge," The Clarendon Press, Oxford, 1940, pp. 240-253.

Because film characteristics vary with emulsion and conditions of exposure and development, a verification of film linearity must be made whenever accurate work is to be done.

A convenient method for calibrating the response of the film and photometer has been developed through the construction of a special aperture in the rotor. Light passing through this rotating aperture produces a graded blackening on the film alongside the image of the centrifuge cell (Fig. 1). The shape of the aperture is chosen so that the photometric record of the graded blackening will be a straight line whenever the conditions expressed by equation 1 are satisfied. The appropriate aperture shape is given by

$$\theta(r) = \exp(K_1 r + K_2) \quad (2)$$

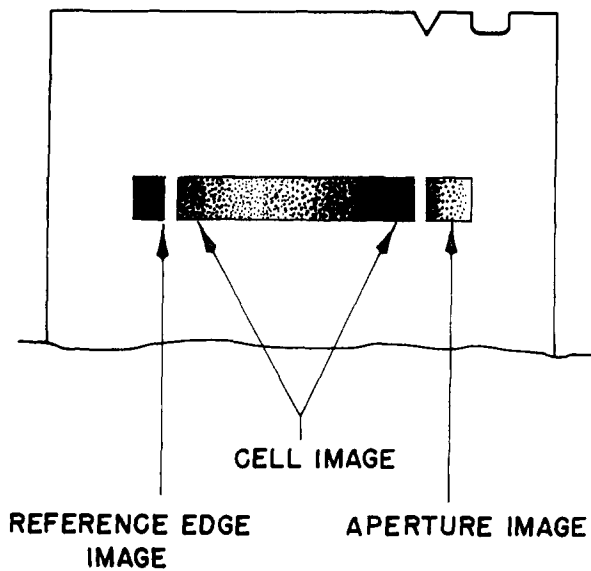

Fig. 1.—Photographic record of absorption optical experiment with aperture image.

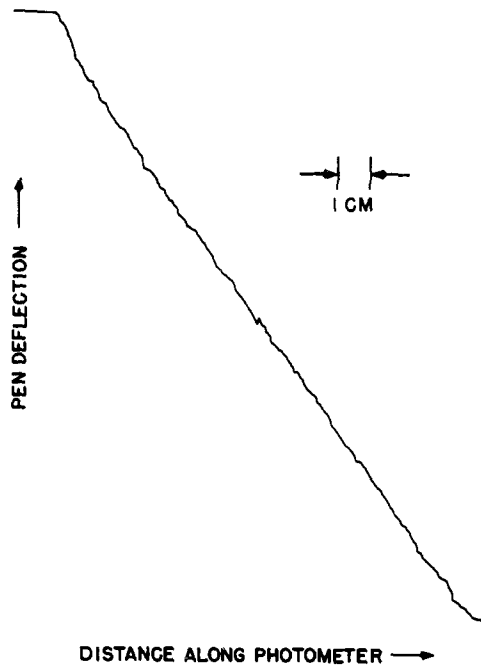

Fig. 2.—Photometer record of entire aperture image.

where $\theta(r)$ is the angular opening in radians at the distance r from the axis of rotation.²

Whenever the photometric recording of the photographic image of the exponential aperture is found to be a straight line (Fig. 2), β may be

$$\beta = \frac{SM}{K_1 \log e} \quad (3)$$

evaluated readily from the relation in which S is the change in pen deflection per unit distance and M is the rotor to photometer magnification factor.

The optical density (O.D.) of the cell is equal to the negative log of exposure of the film to within an additive constant. Thus, for monochromatic

(2) We have chosen the values $K_1 = 9.533 \text{ cm.}^{-1}$ and $K_2 = -57.45$. This results in a range of 2.0 optical density units along the 0.45 cm. length of our rotating aperture.

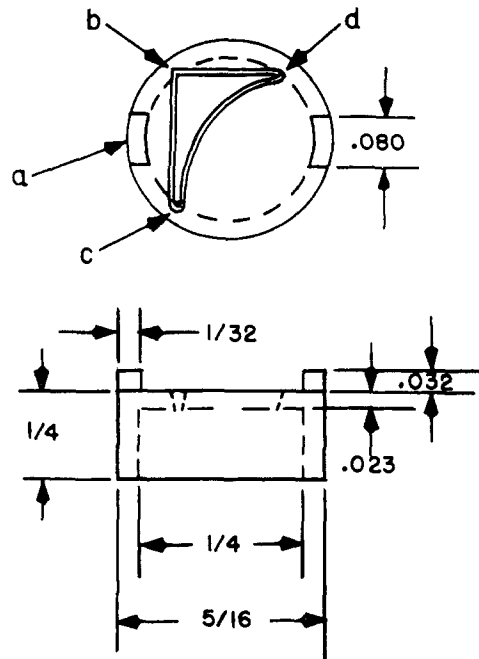

Fig. 3.—Details of aperture assembly. *a* is a tool lug for alignment of aperture. *b* is at 5.75 cm. from axis of rotation. *bc* is aligned radially and is 0.45 cm. long. *bd* is a 4° circular segment.

light from equation 1

$$\beta(\text{O.D.}) = -\text{Pen Deflection} + f_2 \quad (4)$$

Equation 4 may be used to calculate the increment in optical density over any chosen reference density.

The photometer record of the rotating aperture and the analytical cell includes points of equal pen deflection. These correspond to positions in the cell and aperture for which

$$\text{O.D. cell} = \log \frac{\theta \text{ cell}}{2\pi} - \log \frac{\theta \text{ aperture}}{2\pi} \quad (5)$$

Equation 5 is used alone to determine optical density in the cell for the non-linear case in which equation 4 will not be valid. In the linear case equation 4 may be used in conjunction with a single reference density obtained with equation 5 to compute the optical density in the cell.

The contribution of a solute to the photometer pen deflection can sometimes be separated from other contributions by interpolation of a baseline (for example, a DNA band at equilibrium in cesium chloride solution)³ or by extrapolation as in the case of sedimentation velocity experiments. In other experiments the contribution of a solute can be isolated by performing a separate experiment in which the same cell assembly is used to centrifuge solvent alone. The conditions of film exposure and development need not be identical in the separate experiments.

A special assembly has been used to incorporate the exponential aperture in the rotor.⁴ A 64 × pattern of the aperture was constructed and was

(3) M. Meselson, F. W. Stahl and J. R. Vinograd, *Proc. Nat. Acad. Sci.*, **43**, 581 (1958).

(4) In a preliminary assembly the aperture was incorporated in a special counterbalance. This assembly was abandoned because it required alignment before each run and was more difficult to manufacture.

transferred by means of an engraving pantograph onto the bottom of a small cylindrical aluminum cup (Fig. 3); the cup was inserted in a hole bored through the rotor parallel to the axis of rotation, 2.170 inches from the axis and displaced 90° from the analytical cell hole. The hole was counter-bored from the top to leave a supporting shoulder of metal in such a position that the exponential aperture would be at the median plane. The cup was pressed down to the shoulder where it is held in alignment by friction. A similar but blind hole was bored in the symmetric position to main-

tain proper mass distribution. This assembly has been successfully operated at angular speeds up to 56,100 r.p.m.

We wish to thank Mr. G. Harris and Mr. Wm. Scheulke of the Chemistry Division's workshop for their contributions to the solution of problems encountered in the design and construction of the aperture assemblies.

This work was supported in part by grants No. H-3394 and E-1355 of the United States Public Health Service.

PASADENA, CALIFORNIA

[CONTRIBUTION FROM CLARKSON COLLEGE OF TECHNOLOGY]

Influence of Electrolytes on the Light Scattering of Inorganic Compounds. Light Scattering of Phosphotungstic Acids¹

BY E. MATIJEVIĆ² AND M. KERKER

RECEIVED OCTOBER 4, 1958

A light scattering investigation of 9-phosphotungstic acid and 12-phosphotungstic acid in aqueous solution and in the presence of various concentrations of added electrolyte was carried out. The apparent molecular weight in aqueous solution was lower than the formula molecular weight, but it increased with increasing salt concentrations and eventually reached values higher than the formula molecular weight.

The study of solutions of electrolytes by light scattering is beset by numerous difficulties. On the one hand, simple electrolytes, which are amenable to theoretical treatment at moderate concentrations, have low ionic weights and therefore do not scatter light sufficiently intense for quantitative work. On the other hand, there is no satisfactory theoretical treatment for high ionic weight electrolytes such as proteins, micelles and polyelectrolytes, and even an adequate physical model for these is frequently lacking. Intermediate between these two classes of electrolytes are the isopoly and heteropoly compounds and other polynuclear inorganic complexes. They are strong electrolytes of moderately high molecular weight whose kinetic units are fully defined and they can be studied by light scattering.³⁻⁵

In this paper we will present light scattering data for 9-phosphotungstic acid, $H_6P_2W_{18}O_{62}$, (9-PTA), and 12-phosphotungstic acid, $H_7PW_{12}O_{42}$, (12-PTA), in aqueous solution and in the presence of added electrolyte. Earlier work has established the above molecular formulas and demonstrated that these substances are practically completely ionized in dilute solutions.^{3,6,7}

Experimental

Materials. 1. **12-Phosphotungstic Acid.**—The reagent grade acid available from J. T. Baker Company was purified by the following procedure. One hundred g. was dissolved in 75 ml. of water and transferred to a separatory

funnel. A few drops of concd. HNO_3 were added and the phosphotungstic acid was extracted with ether. The acid-ether complex (the lowest of the three layers) was separated, washed several times with 2 N HCl, then with water and again extracted with ether. The ether was finally evaporated *in vacuo* with mild heating on a water-bath, the crystals dried *in vacuo* and ground. The moisture was determined by drying to constant weight at 200°.

2. **9-Phosphotungstic Acid.**—This was prepared as described by Wu⁸ and modified by Souchay⁹ and Kerker, *et al.*³ First the ammonium salt was obtained and purified by several precipitations with ammonium chloride and then the free acid was prepared by dissolving the salt in HCl (1:1) and extracting with ether. Several subsequent extractions were performed to secure a pure and salt-free 9-phosphotungstic acid. The ether complex was freed from ether by evaporation and drying *in vacuo*.

Both phosphotungstic acids gave clear solutions even when dissolved in very high concentrations. On the other hand, solutions of the unpurified commercial 12-PTA were quite turbid and could only be clarified by filtration with considerable difficulty.

3. Nitric acid and potassium chloride were of the highest purity grade commercial chemicals. The latter was recrystallized before use. Water was distilled twice, the second time from an all-Pyrex still. All glassware was thoroughly cleaned and steamed before use.

Experimental Technique.—The solutions of phosphotungstic acid used for measurements were obtained either by direct weighing of the solid substance or by dilution of a stock solution of high concentration with water or with a solution containing added electrolyte (KCl, HNO_3) of the same concentration as the stock solution.

In order to obtain optically clear, dust-free solutions, they were filtered through an ultrafine glass filter (Pyrex UF) under pressure of nitrogen. Firstly an aliquot of the solution was filtered several times and discarded, and then the main portion of the solution was filtered through the same filter directly into the light scattering cell. In a number of cases the filtrate was quantitatively analyzed and no loss during the filtration could be found. When solutions were prepared by dilution, the filtration was not always necessary as the filtered stock solution was diluted carefully with the filtered solvent and no contamination by dust or lint permitted during the operation of dilution.

(1) Supported by U. S. Atomic Energy Commission Contract No. AT (30-1)-1801.

(2) On leave of absence from the Faculty of Science, University, Zagreb, Yugoslavia.

(3) M. Kerker, D. Lee and A. Chou, *THIS JOURNAL*, **80**, 1539 (1958).

(4) D. J. Bettinger and S. Y. Tyree, Jr., *ibid.*, **79**, 3355 (1957).

(5) J. K. Ruff and S. Y. Tyree, Jr., *ibid.*, **80**, 1523 (1958).

(6) E. Matijević and M. Kerker, *J. Phys. Chem.*, **62**, 1271 (1958).

(7) M. Kerker, E. Matijević and W. A. Light, Paper read at the 134th meeting American Chemical Society, Chicago, Ill., Sept. 1958.

(8) H. Wu, *J. Biol. Chem.*, **43**, 189 (1920).

(9) P. Souchay, *Bull. soc. chim. France*, 365 (1951).